

SysLine S

- de Montageanleitung
- br Instruções de montagem
- cz Montážní návod
- dk Monteringsvejledning
- en Installation instructions
- es Instrucciones de montaje
- fi Asennusohje
- fr Instructions de montage
- it Istruzioni di montaggio
- nl Montagehandleiding
- pl Instrukcja montażu
- ru Инструкция по монтажу
- se Monteringsanvisning
- tr Montaj kılavuzu
- ko 설치 설명서
- ja 金具 取付けマニュアル
- zv 安裝說明

Technik für Möbel

Hettich



9 208 511
9 134 311
9 136 103



2 - 3



4 - 8



9 - 15



de Bestimmungsgemäße Verwendung

Der Möbelbeschlag SysLineS wird für obenlaufende Schiebetürsysteme verwendet.

Er ist für die Verwendung in Möbeln nach EN14749 und den Einsatz in geschützten, trockenen Innenräumen vorgesehen.

Eine andere als die unter „Bestimmungsgemäße Verwendung“ festgelegte Verwendung gilt als nicht bestimmungsgemäß.

Der Beschlag ist getestet nach EN15706, Level 3.

Die Dämpfungskomponenten sollten jederzeit zugänglich sein. Dies erreichen sie durch demontierbare Laufprofile oder eine entsprechende Schrankkonstruktion.

br Uso para os fins previstos

A ferragem SysLineS é usada para sistemas de portas de correr com guia superior.

Ela é projetada para a utilização em móveis conforme a norma EN 14749 e em ambientes fechados protegidos e secos.

Qualquer utilização divergente daquela referida em „Uso para os fins previstos“ será considerada como não sendo para os fins previstos.

A ferragem foi testada de acordo com a norma EN 15706, nível 3. Os componentes de amortecimento devem estar sempre livremente acessíveis. Uma maneira de garantir isso é usando perfis de rolamento desmontáveis ou uma estrutura de armário adequada.

CZ Použití v souladu s určením

Nábytkové kování SysLineS se používá pro systémy posuvných dveří s horním nosným profilem.

Je určeno do nábytku podle EN 14749 a pro použití v chráněných a suchých interiérech.

Jiné použití, než které je definované pod bodem „Použití v souladu s určením“ se považuje za nesprávné.

Kování je testováno podle EN 15706, úroveň 3. Součásti tlumení mají zůstat kdykoliv přístupné. Toho dosáhnete použitím demontovatelných nosných profilů nebo odpovídající konstrukcí skříně.

dk Tilsigtet brug

Møbelbeslaget SysLineS anvendes til skydelågesystemer, der er monteret foroven.

Det er beregnet til anvendelse i møbler i overensstemmelse med EN 14749 og anvendelse i beskyttede, tørre indendørs rum.

En anden anvendelse end den, der er fastlagt under „Tilsigtet brug“, anses for at være utilsigtet.

Beslaget er testet i overensstemmelse med EN 15706, Level 3. Dæmpningskomponenterne skal altid være tilgængelige. Dette opnår du vha. demonterbare køreskinner eller en passende skabskonstruktion.

en Intended Use

The SysLineS furniture fitting is used for top running sliding door systems.

It is intended for application in furniture to EN14749 and use in dry indoor environments where it is protected from the elements.

Any use other than that defined under „Intended Use“ will be deemed to be non intended use.

The fitting is tested under EN 15706, Level 3. The Silent System components should be accessible at all times. This can be achieved by using removable runner profiles or by designing a cabinet to let you do this.

es Utilización conforme al uso previsto

El herraje de mueble SysLineS se utiliza para sistemas de puertas correderas de deslizamiento superior.

Está previsto para el uso en muebles según EN 14749 y su aplicación en recintos protegidos y secos.

Cualquier otra utilización que difiera de la „Utilización conforme al uso previsto“ se considera no conforme a lo previsto.

El herraje se ha sometido a comprobación según EN 15706, nivel 3. Los componentes de amortiguación deben encontrarse en todo momento accesibles. Esto mismo se consigue por medio de perfiles de rodadura desmontables o la construcción pertinente de acero.

fi Käyttötarkoitus

SysLineS-kalustehelaa käytetään yläkantoisille liukuovijärjestelmille.

Se on tarkoitettu käytettäväksi EN14749 -normin mukaisissa huonekaluissa suojaetuissa, kuivissa sisätiloissa.

Muunlainen kuin kohdassa „Käyttötarkoitus“ mainittu käyttö ei ole käyttötarkoituksen mukaista käyttöä.

Hela on testattu normin EN 15706, Level 3, mukaisesti. Vaimennusosiin tulee päästä käsiksi esteittä. Tämä on mahdollista käyttämällä irrotettavaa profiilikiskoa tai vastaavaa kaapin rakennetta.

fr Utilisation conforme à la destination prévue

La ferrure de meuble SysLineS est utilisée pour les systèmes de portes coulissantes par le haut.

Elle est prévue pour une utilisation dans des meubles conformément à la norme EN 14749 et, à l'intérieur, dans des pièces non humides et protégées.

Toute utilisation autre que celle indiquée dans l'«utilisation conforme à la destination prévue» sera considérée comme non conforme.

La ferrure est testée selon la norme EN 15706, niveau 3. Les pièces d'amortissement devraient être toujours accessibles. Vous y parvenez en utilisant des profilés de coulissage démontables ou une construction de meubles adéquate.

it Uso conforme alla destinazione

Il dispositivo per mobili SysLineS si applica a sistemi per ante con scorrimento sul binario superiore.

Il suo uso è previsto in mobili conformi alla norma EN14749 e in ambienti interni protetti e asciutti.

Ogni altro utilizzo diverso da quanto indicato al punto “Uso conforme alla destinazione” è da considerarsi non conforme.

Il sistema è testato secondo la EN 15706, Level 3. I componenti dell'ammortizzatore devono sempre essere accessibili. Ciò è possibile se si applicano binari di scorrimento smontabili o progettando adeguatamente la struttura del mobile.

--- Doelmatiggebruik

Het meubelbeslag SysLine S wordt voor bovenaan lopende schuifdeur-systemen gebruikt.

Het is gemaakt voor gebruik in meubels volgens EN 14749 en toepassing in beschutte, droge binnenruimtes.

Elk ander gebruik dan vastgelegd onder ‚Doelmatig gebruik‘ geldt als zijnde niet volgens de voorschriften.

Het beslag werd getest conform EN 15706, level 3. De dempingscomponenten zouden altijd toegankelijk moeten zijn. Dit bereikt u door demonteerbare loopprofielen of een aangepast kastconstructie.

pl Zastosowanie zgodne z przeznaczeniem

Okucie meblowe SysLine S stosowane jest do systemów do drzwi przesuwanych z górnym mechanizmem jezdnych.

Przeznaczone jest do zastosowania w meblach zgodnie z EN 14749 oraz do zastosowania w osłoniętych, suchych pomieszczeniach wewnętrznych.

Zastosowanie inne niż określone jako „Zastosowanie zgodne z przeznaczeniem“

jest niezgodne z przeznaczeniem.

Okucie zostało przetestowane zgodnie z EN 15706, poziom 3. Elementy amortyzacji powinny być zawsze łatwo dostępne. Zapewniają to demontowalne profile jezdne lub odpowiednia konstrukcja szafy.

ru Использование по назначению

Фурнитура SysLine S используется для систем с раздвижными дверями с верхним ходовым профилем.

Фурнитура предназначена для применения в мебели согласно стандарту EN 14749, в сухих закрытых помещениях. Любое другое использование, не определенное данной инструкцией, считается использованием не по назначению.

Фурнитура прошла тестирование в соответствии с нормами EN 15706, Уровень 3.

Необходимо обеспечить постоянный доступ к компонентам системы демпфирования Silent System. Этого можно достичь, используя съемный ходовой профиль или соответствующим образом спроектировав шкаф.

se Ändamålsenlig användning

Möbelbeslaget SysLine S används för topplöpande skjutdörrsystem.

Beslaget är avsett att användas i möbler enligt EN 14749 och i skyddade, torra utrymmen inomhus.

All annan användning än den som anges under „Ändamålsenlig användning“ gäller som ej ändamålsenlig.

Beslaget är testat enligt EN 15706, nivå 3. Dämpningskomponenterna bör alltid vara tillgängliga. Detta uppnås genom avtagbara löpprofiler eller en passandeskåpkonstruktion.

tr Amacına uygun kullanım

SysLine S mobilya metal aksamlı, üstten çalışan sürgü kapak sistemlerinde kullanılır.

Bu ürün, EN 14749 standardına uygun mobilyalar içinde ve kuru, korunmuş iç mekanlarda kullanım için öngörülmüştür.

„Amacına uygun kullanım“ başlığı altında öngörülenin dışındaki bir kullanım, amacına aykırı olarak nitelendirilir.

Mobilya aksamlı EN 15706, Seviye 3 uyarınca test edilmiştir. Fren sistemi bileşenleri daima erişilebilir halde olmalıdır. Bu ancak, sökülebilir hareket profilleri veya uygun bir dolap konstrüksiyonu ile sağlanır.

ko 사용용도

SysLine S 가구 피팅은 상부 러닝방식의 슬라이딩 도어 시스템입니다.

EN 14749에 따라 인증된 가구용 피팅으로서 손상을 방지하기 위해 건조한 실내에서 사용해야 합니다.

제시된 목적 이외의 용도에는 사용할 수 없습니다.

이 피팅은 EN 15706, Level 3에 따라 테스트 완료 하였습니다.사일런트 시스템 컴포넌트는 교체가능한 러닝 프로파일을 사용하거나 또는 이것이 가능한 캐비닛을 디자인함으로써 항상 작동이 용이할

ja 用途

シスラインSは上吊り式のスライドドア用金具です。ドイツの環境規定 EN 14749に準じ、室内での使用を想定しておりますのでそれ以外の用途ではご使用いただけません。また、ドイツ工業規格 EN 15706 Level 3をクリアしています。サイレントシステム(ダンパー)が装備されました。

zh 推荐用途

SysLine S 配件用于家具中的顶部滑动移门系统。可应用于 EN 14749 标准列明的室内干燥环境保护下的家具中。

任何未在推荐用途中使用的情況将被定义为非预期使用。

该配件通过 EN 15706 标准三级测试。Silent System 静音阻尼系统组件应全时间配置。这可以通过使用可拆卸滑动轨道或在橱柜设计中标明实现。

i

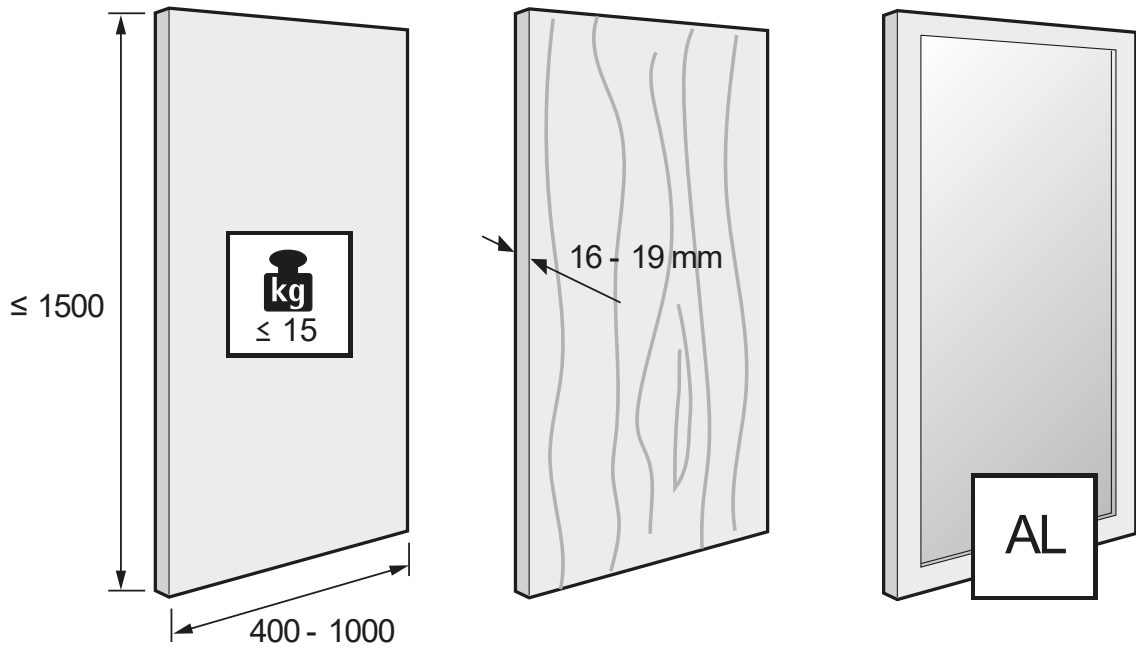

i

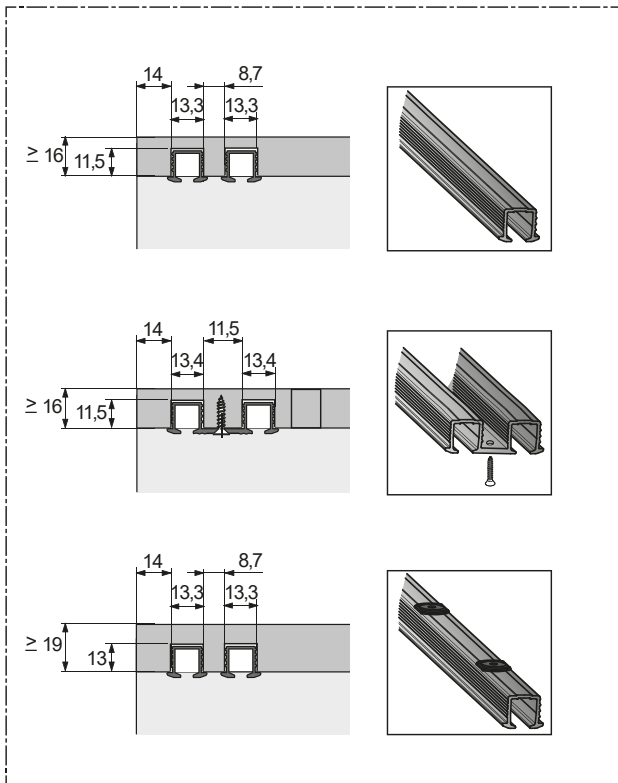
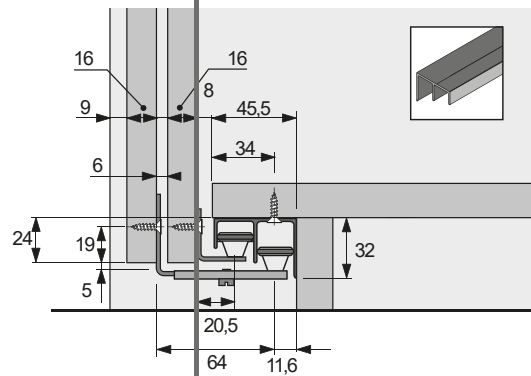
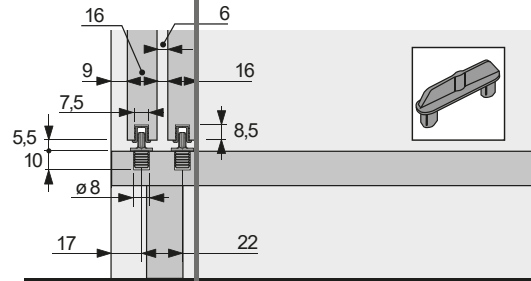
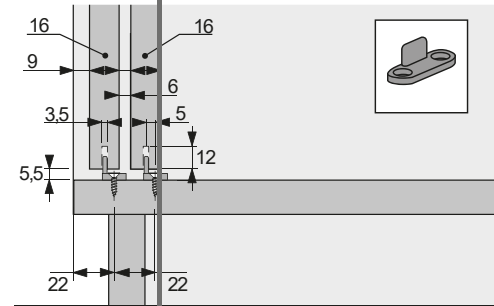
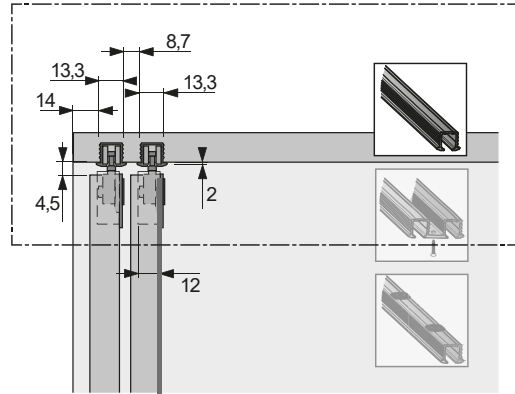
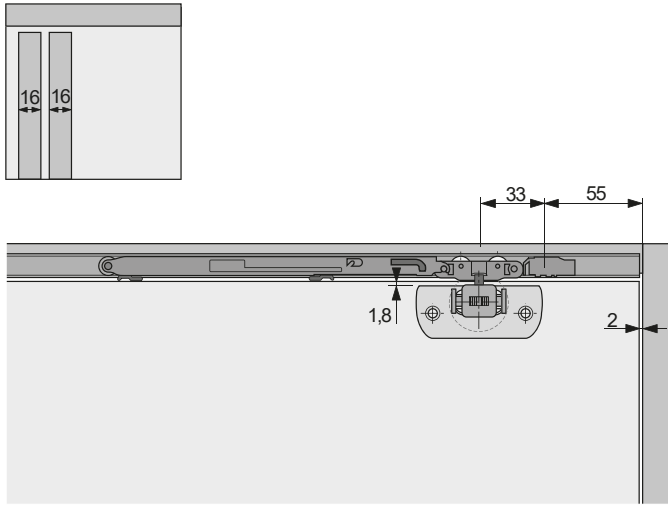

i

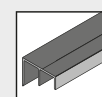
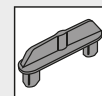
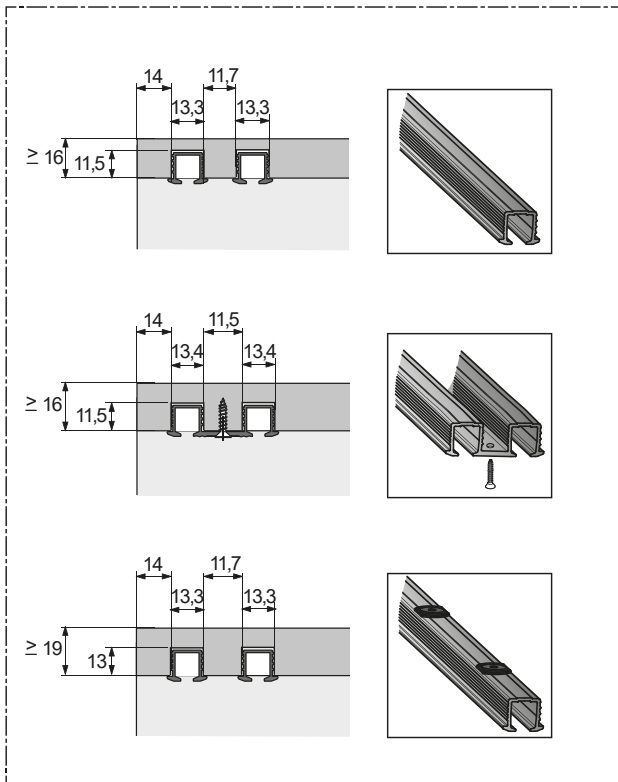
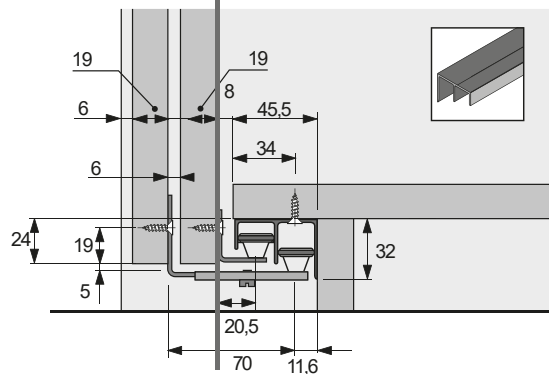
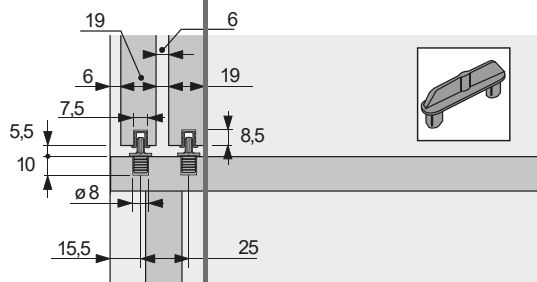
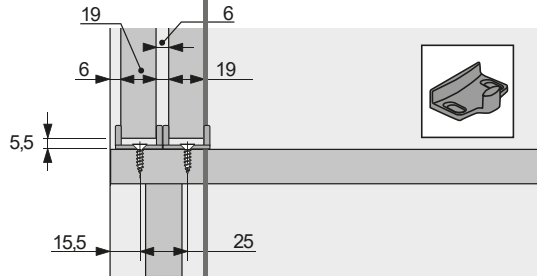
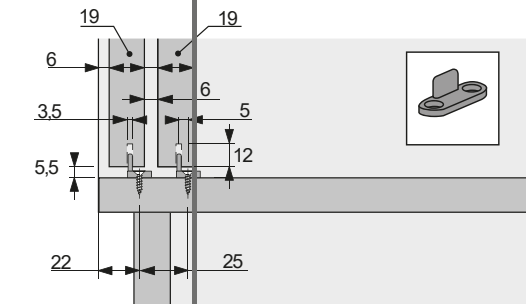
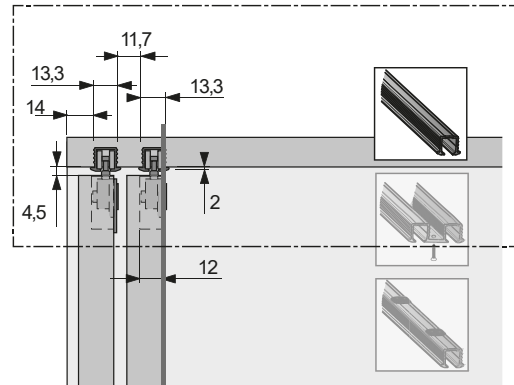
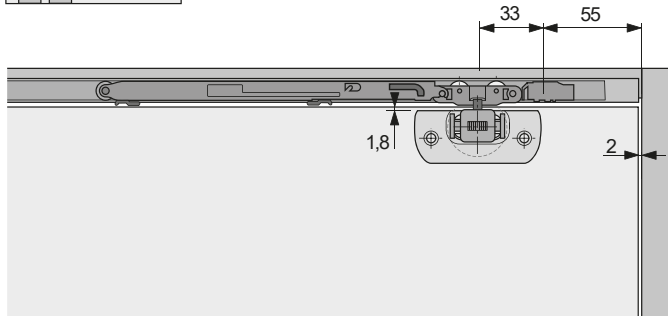
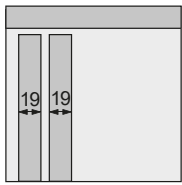

i

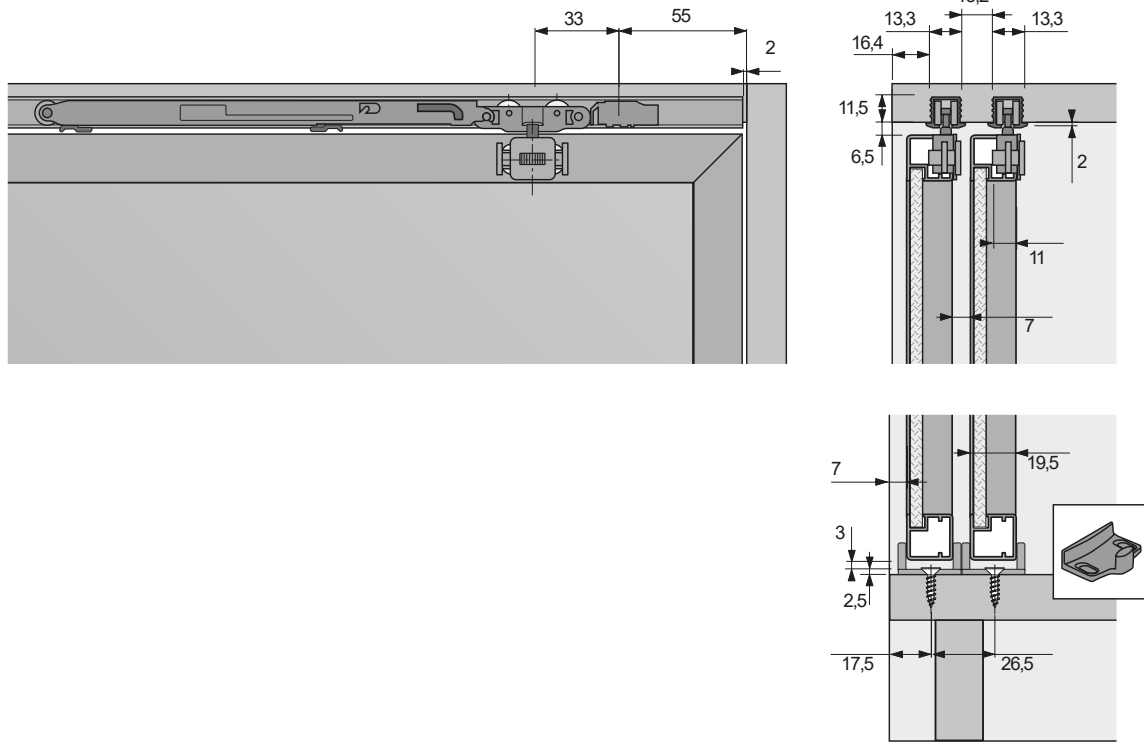

i

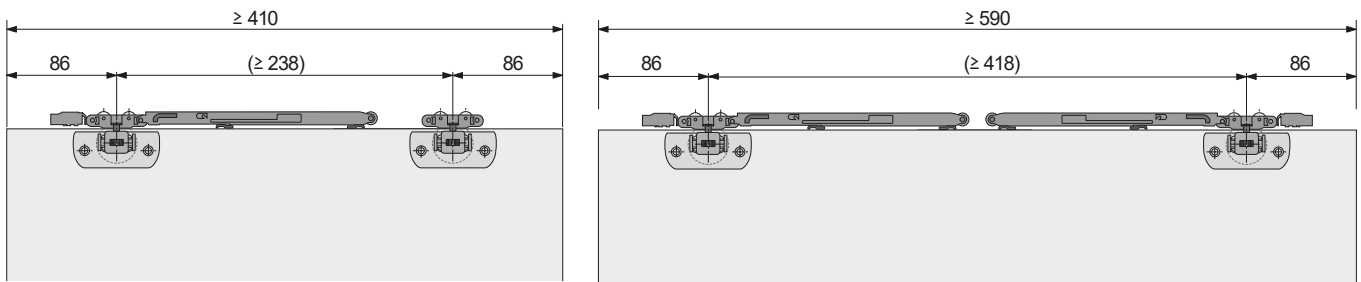

i

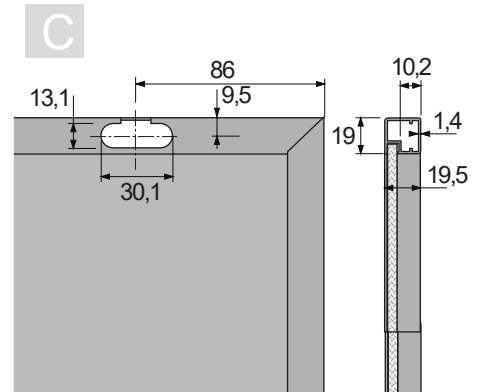
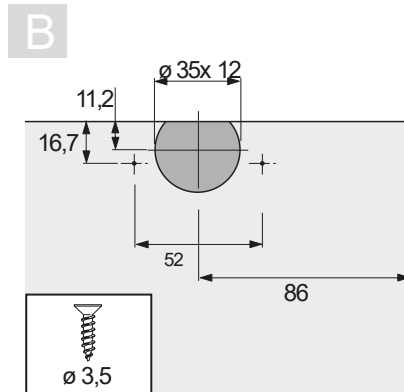
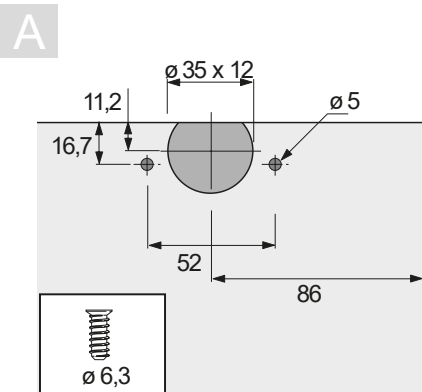

i A

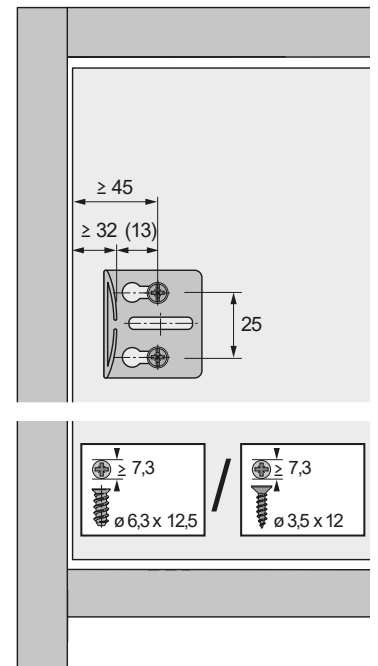
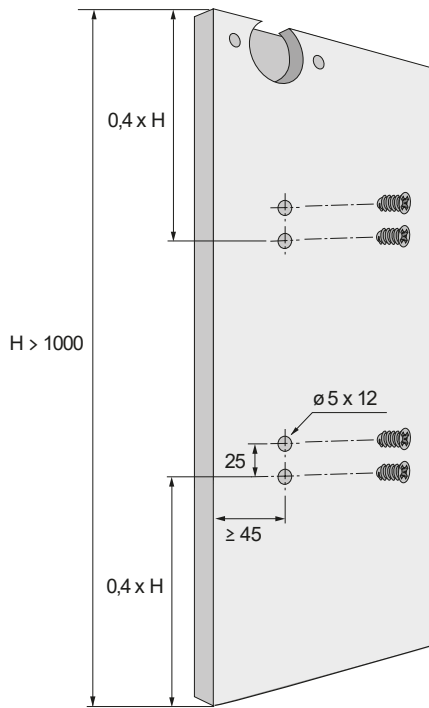
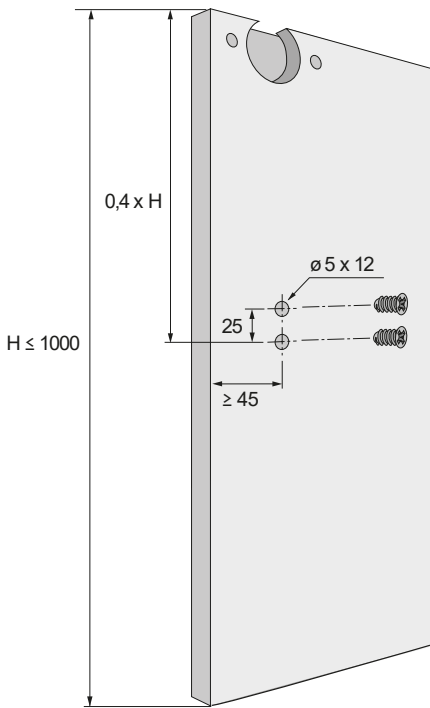
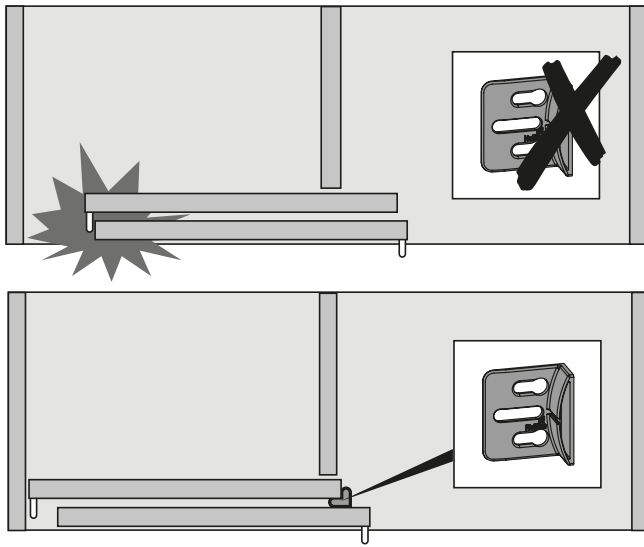

B

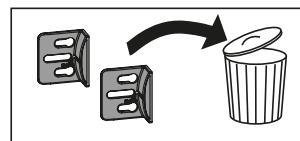
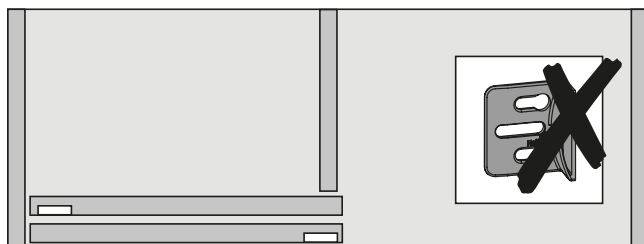



1

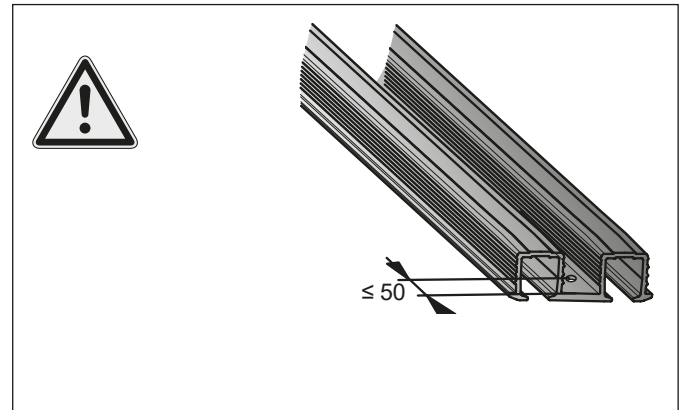
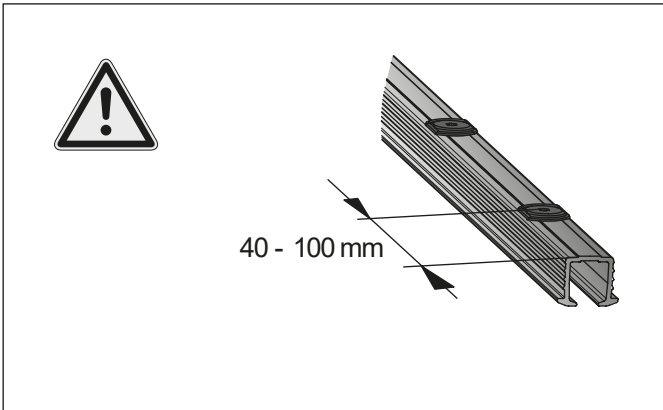
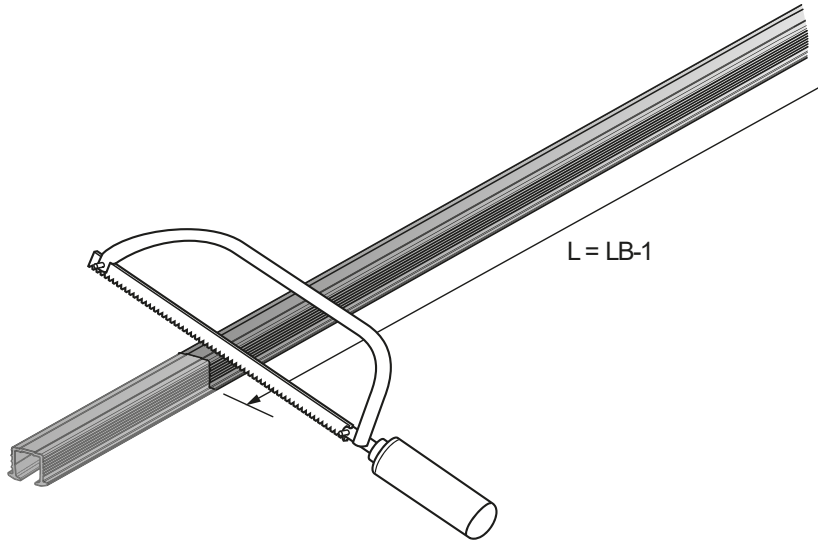
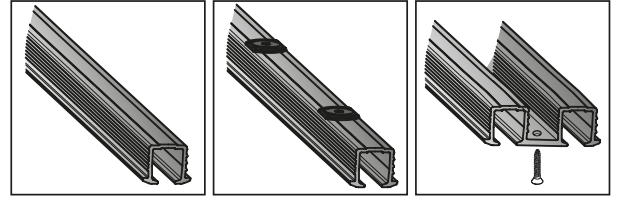
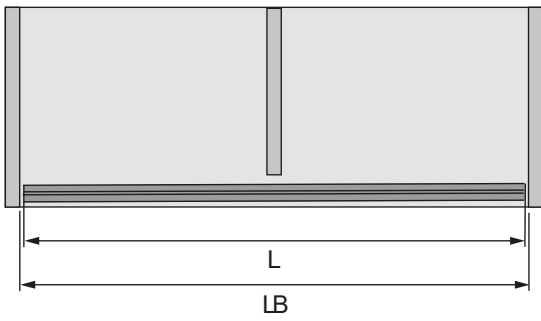



2

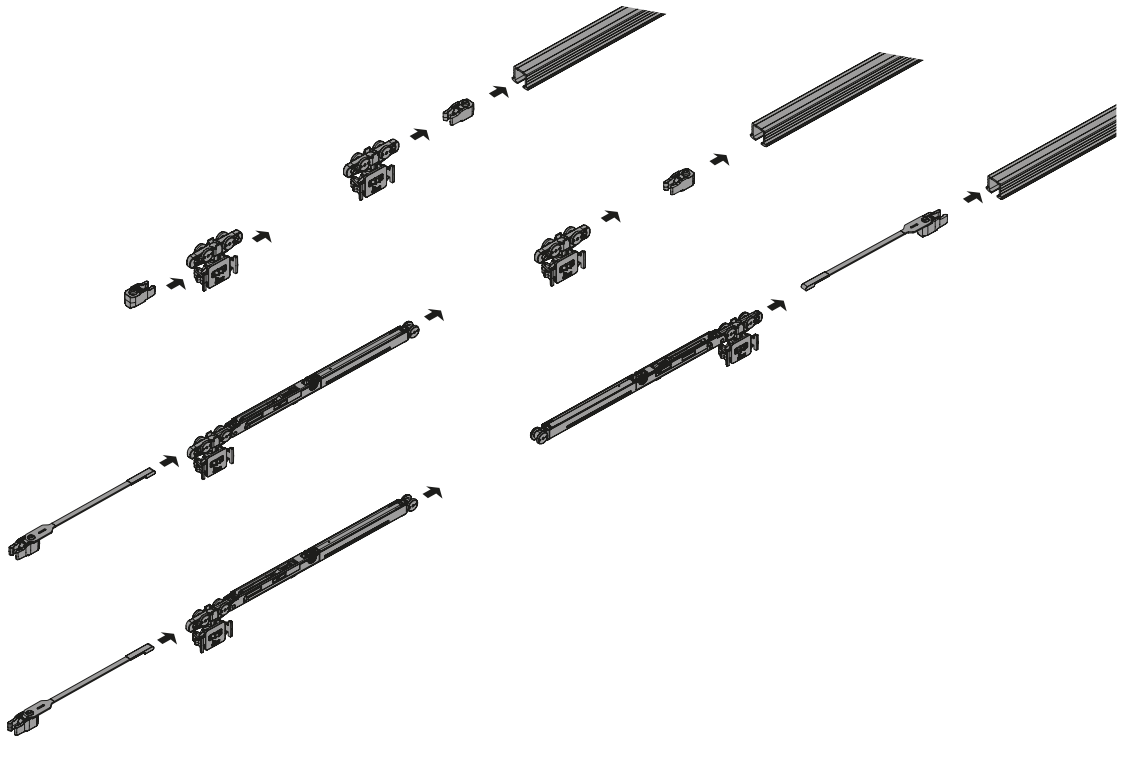
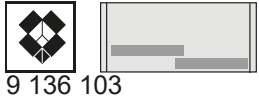

3

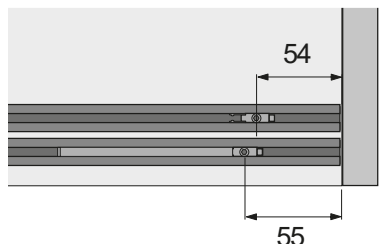
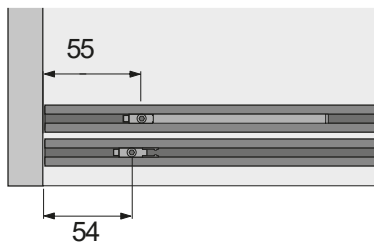
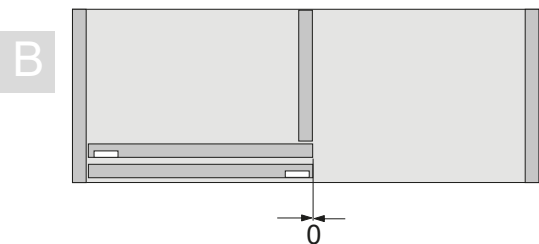
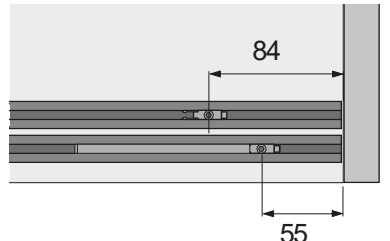
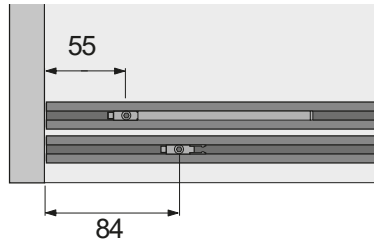
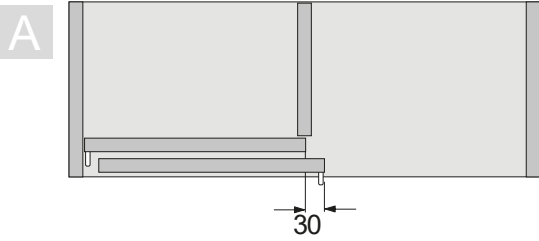
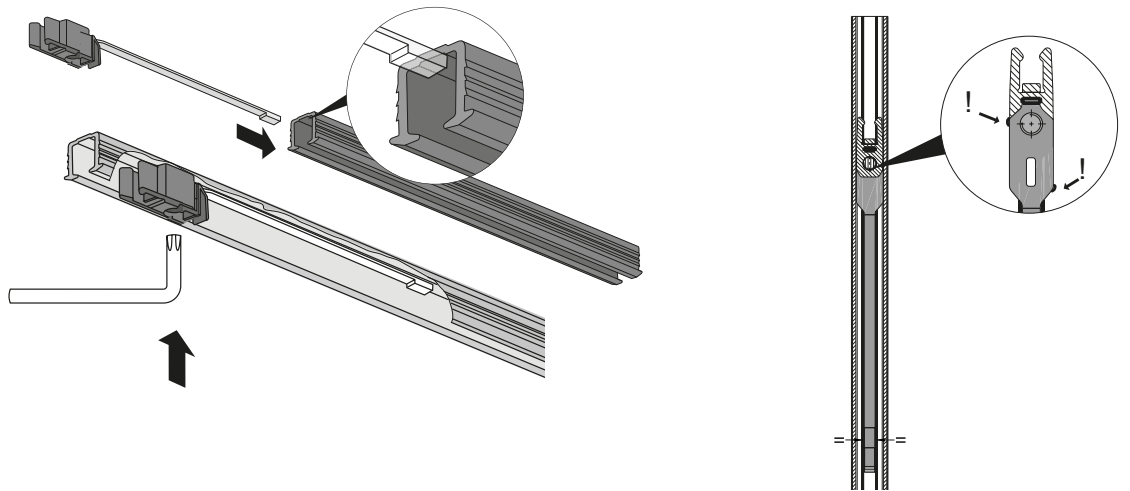
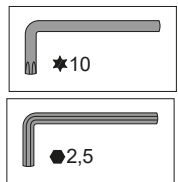

4

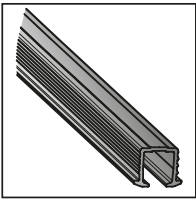

A

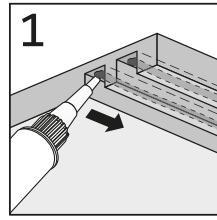

Jowapur 685.32
Jowapur 685.52

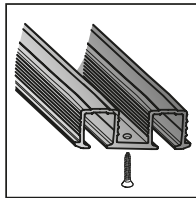
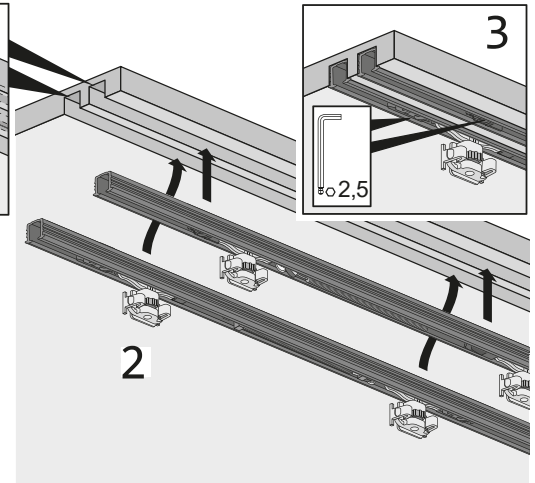
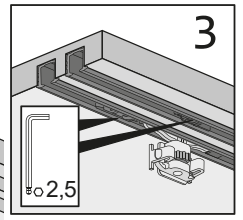

B

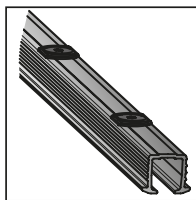
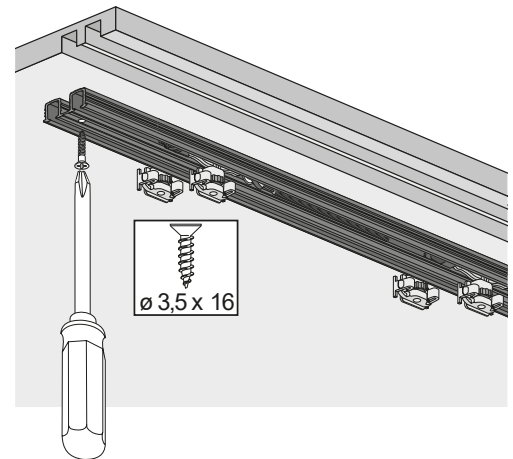

C

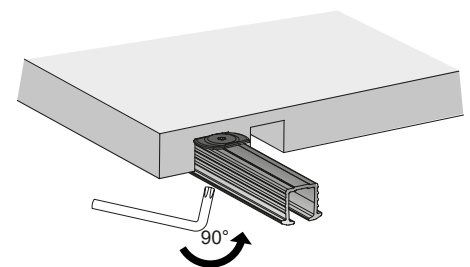
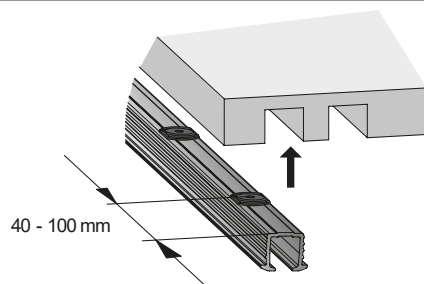

de * Nicht für Hartholz und MDF verwendbar.
br * Não é para madeira e MDF.
cz * Nelze použít pro tvrdé dřevo a MDF.
dk * Ikke for træ og MDF.
en * Cannot be used for hardwood and MDF.
es * No aplicable en maderas macizas ni en MDF.
fi * Ei puu ja MDF.
fr * Ne convient pas pour bois durs et MDF.
it * Non utilizzare su legno massiccio e MDF.

nl * Niet geschikt voor hard hout en MDF.
pl * Nie należy używać w przypadku twardego drewna i MDF.
ru * Не подходит для древесины и МДФ.
se * Inte för trä och MDF.
tr * Değil ahşap ve MDF için.
ko * 사용용도
ja * MDFや硬い材質にはご使用いただけません。
zh * 不為木材和中密度板。



5

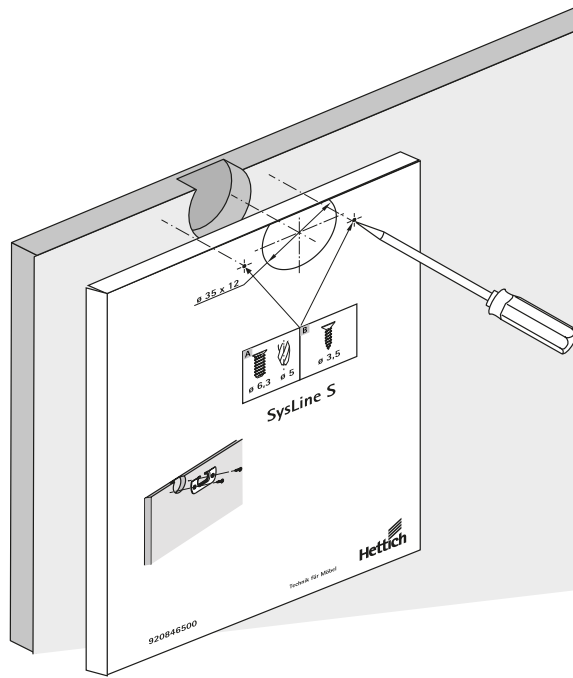

6

A

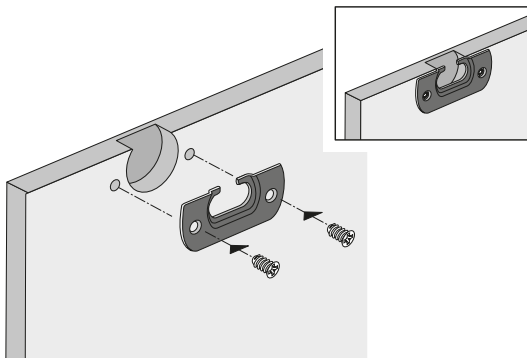

B

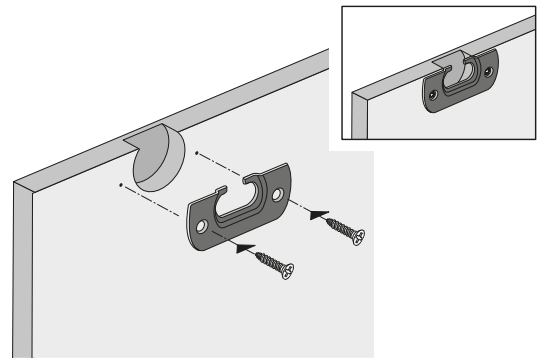

7

A

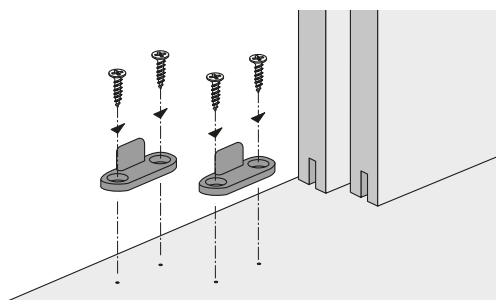

B

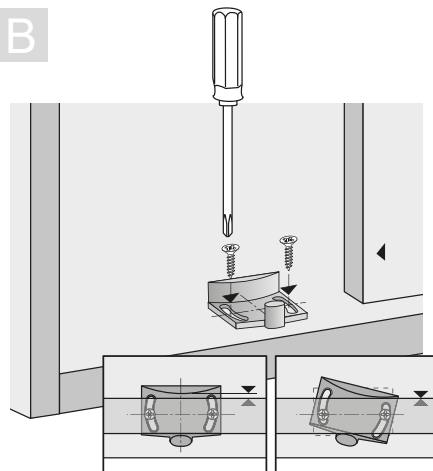

C

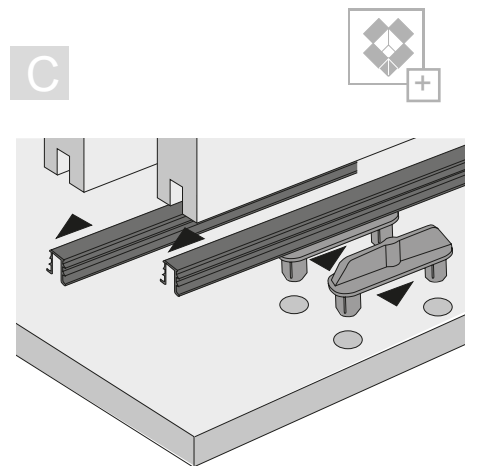

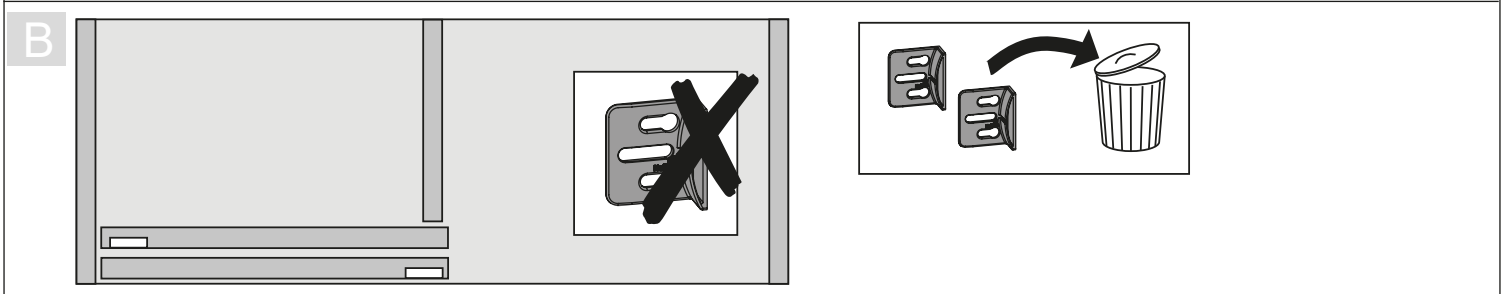
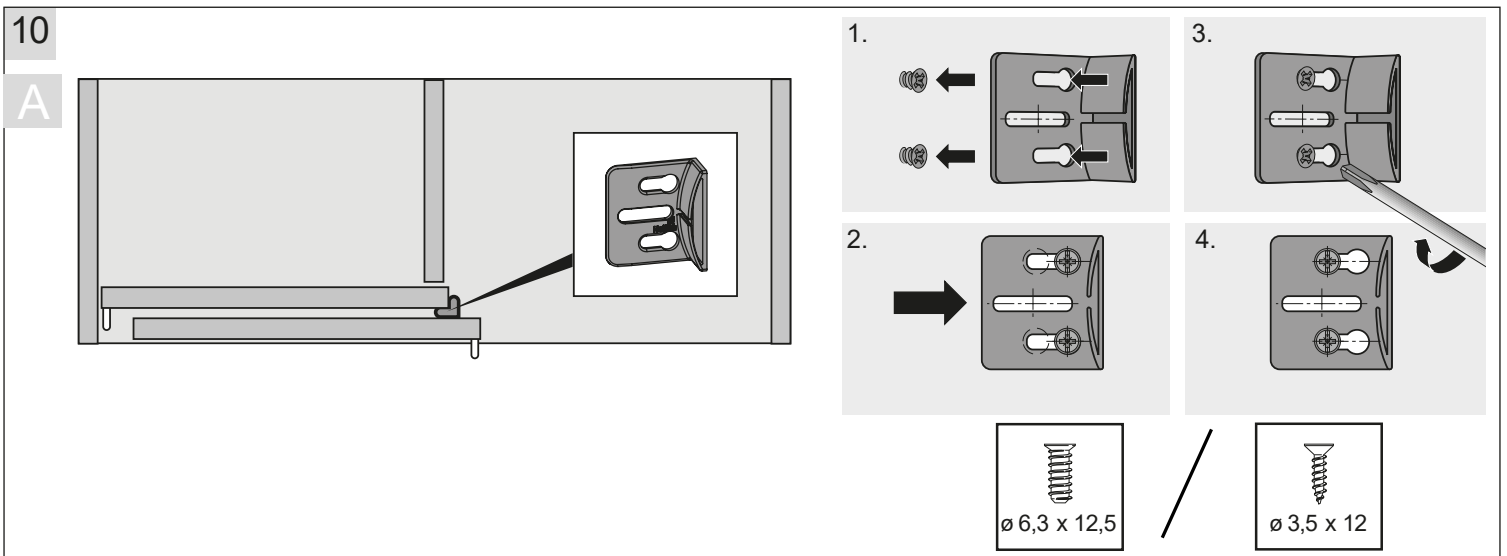
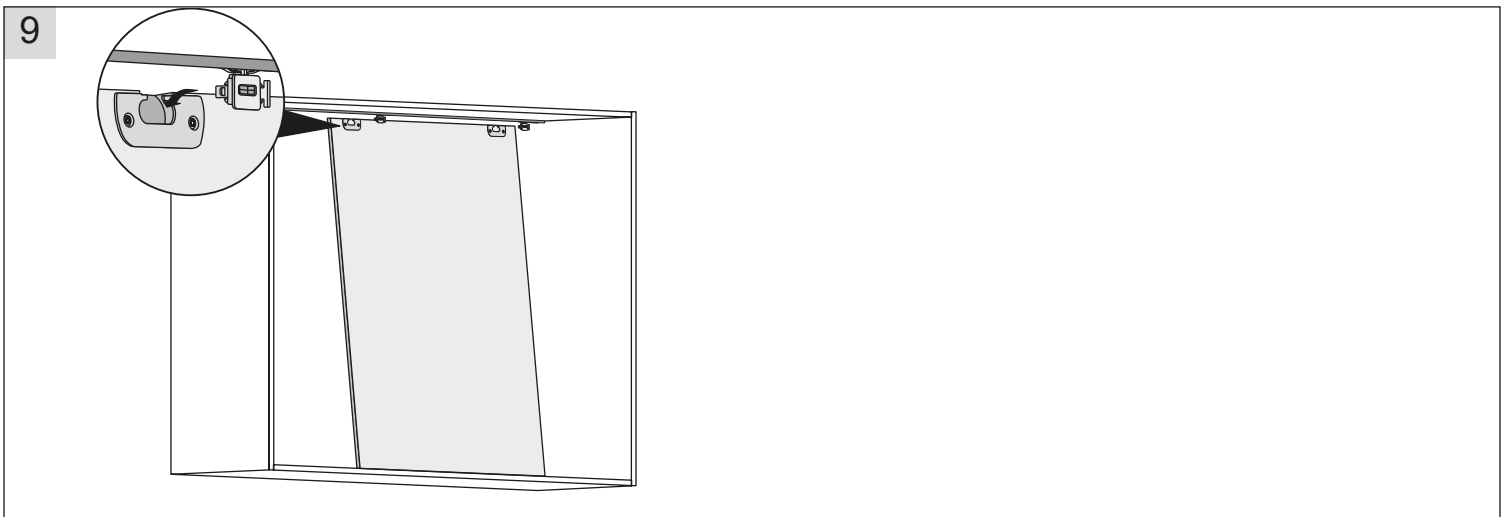
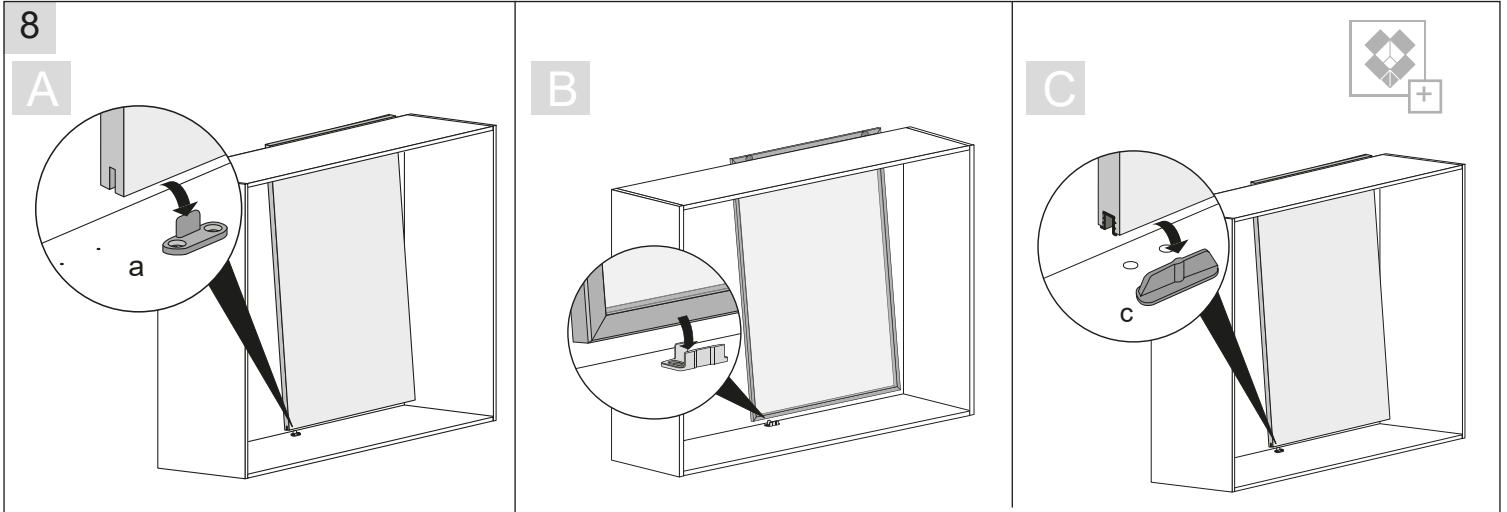



11

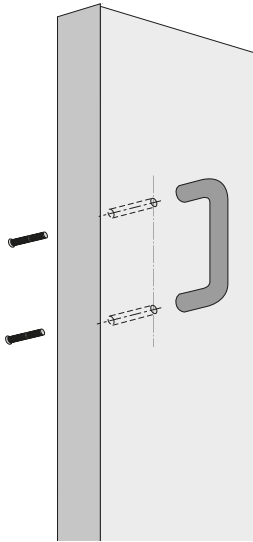

12

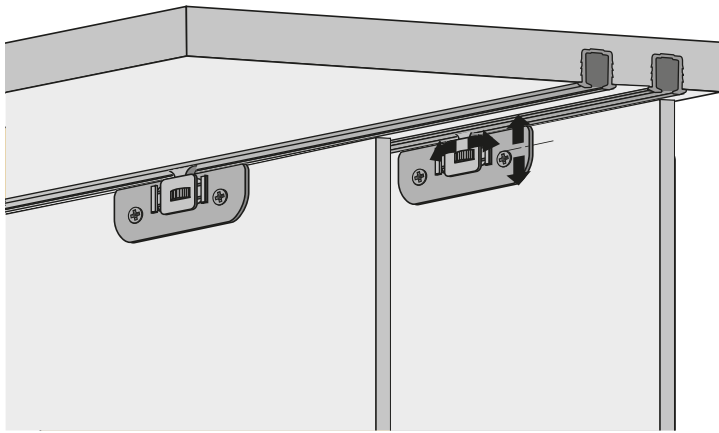

13

A

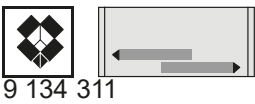

9 134 311

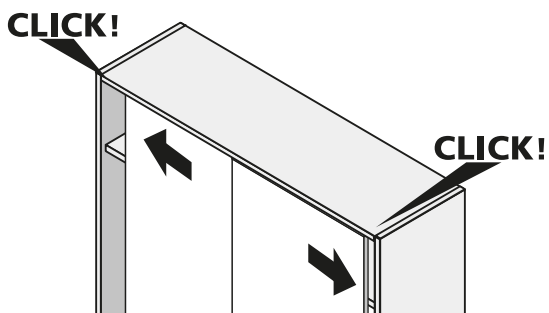

B

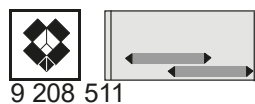

9 208 511

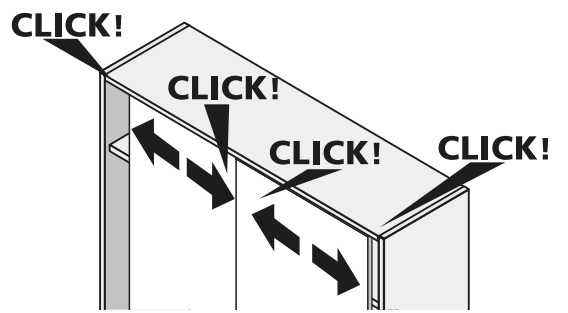



i

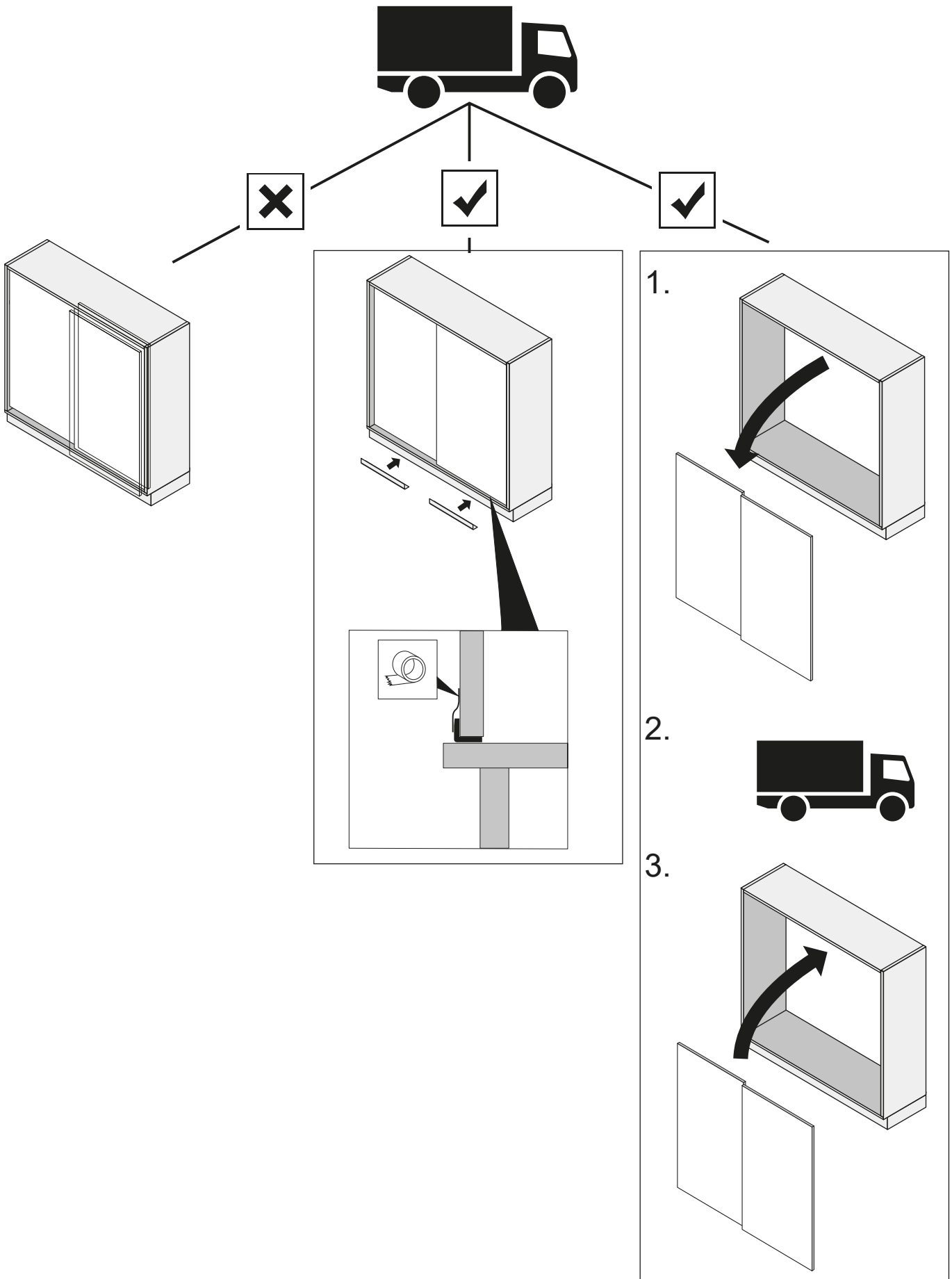

©Hettich Marketing- und Vertriebs GmbH & Co. KG

Der Nachdruck dieser Montageanleitung, auch auszugsweise, ist nur mit schriftlicher Einwilligung der Hettich Marketing- und Vertriebs GmbH & Co. KG zugelassen.

Sämtliche in dieser Montageanleitung genannten Bezeichnungen von Erzeugnissen sind Marken-/Warenzeichen der jeweiligen Firmen.